

winterhalter

Spare parts list GS 215

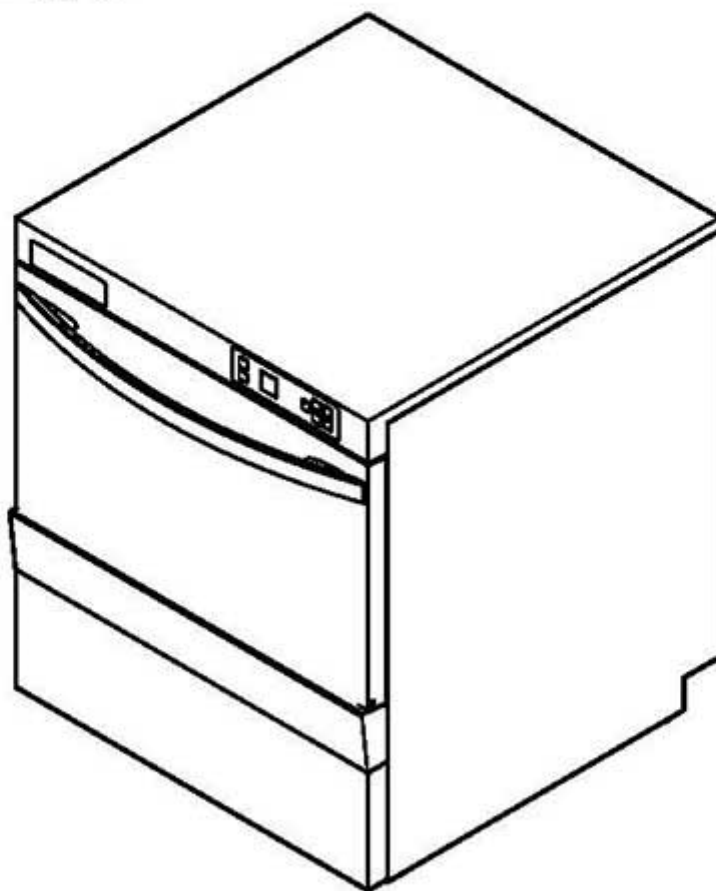

Drawn up: 09/01

Processed: 02.08.09

Parts no.: 89007361

Contents

Water inlet	Page 1 - 2
Water softener	Page 3 - 4
Water drain	Page 5 - 6
Wash pump	Page 7 - 8
Bottom washing/rinsing system	Page 9 - 10
Rinse system top	Page 11 - 12
Pressure boiler	Page 13 - 14
Pressure-independent boiler	Page 15 - 18
Dosage	Page 19 - 20
Chassis, container and panelling	Page 21 - 22
Door	Page 23 - 24
Electric parts	Page 25 - 28

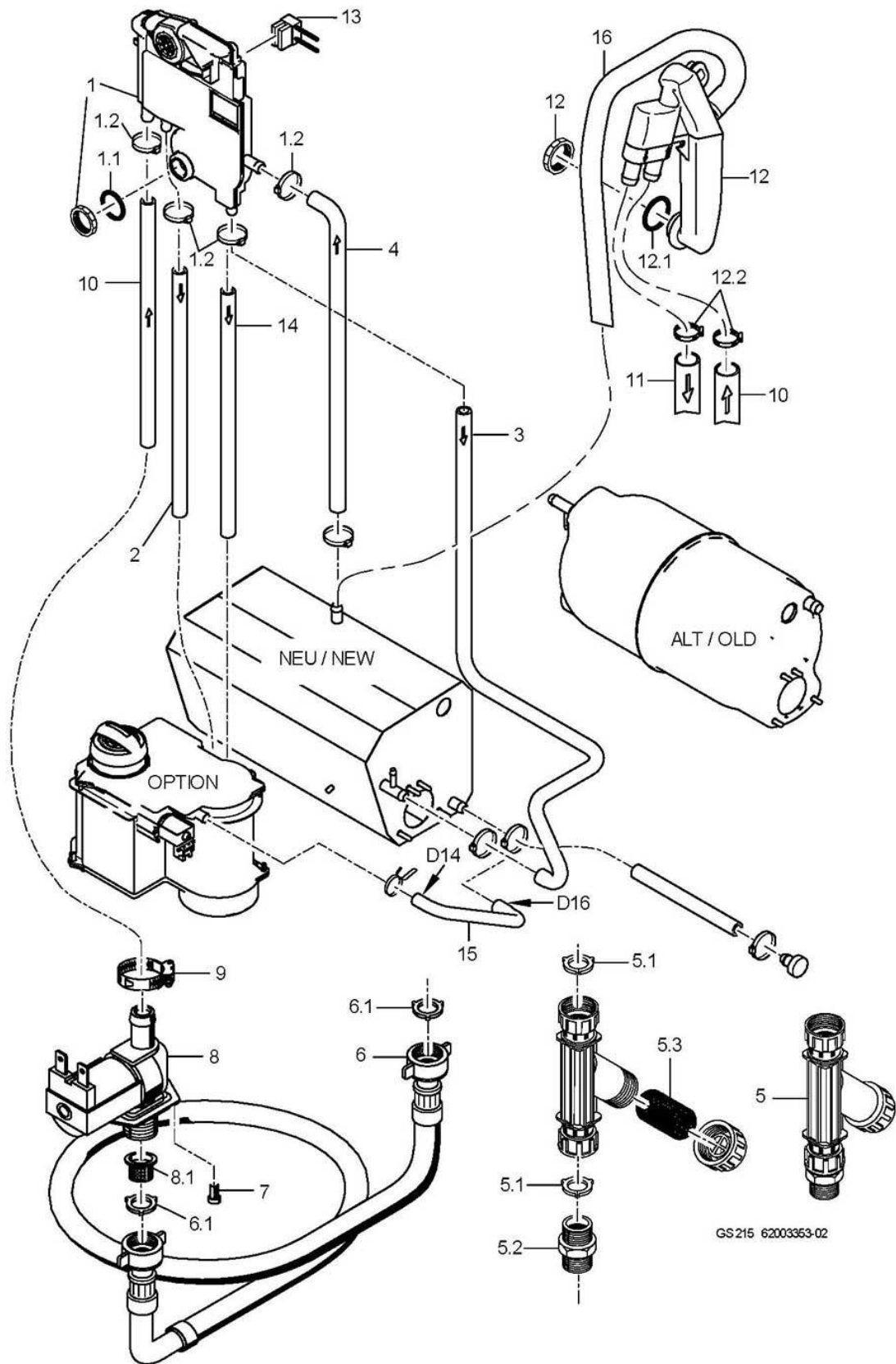

GS 215

Water inlet

Item.	Designation	Parts no.:	Pc.	Notes
1	Set of WSE without impeller counter	60003511		For machines without integrated water softener in the UK and Australia only
1	WSE with impeller counter kit	60003512		for machines with built-in water softener
1.1	O-ring; 24 X 3,0	27 07 087		
1.2	Hose clamp; D12-22 X 9	28 02 105	4	
2	Hose; DN10 X 2,0	40 01 050		710 mm; "By-the-metre" goods
3	Shaped hose; DN10 X DN12 X 3,5	62003089		to machine no.: 527 466
3	Shaped hose; DN10,5 X DN12; 818	60004085		From machine no.: 527 467
4	Shaped hose; DN12,5 X 3,5	62003104		to machine no.: 527 466
4	Shaped hose; DN12 X 3,0 X 491	60004084		From machine no.: 527 467
5	Dirt trap; 150 µM	80002153		
5.1	Gasket; D16 X D24 X 3,0	80002241	3	
5.2	Double nipple; G 3/4" X 40; SW30	80002167		
5.3	Strainer; D27 X 67 X 150µM	80002728		
6	Water supply hose; DN13 X 3,5; 2500	40 02 060		
6	Water supply hose; DN13 X 3,5; 1500	40 02 045		
6.1	Gasket; D16 X D24 X 3,0	80002241	2	
7	Countersunk screw, M4 X 8	20 10 309	2	
8	Solenoid valve flow restrictor 15l; 230-240V 50/60HZ RAST5	31 06 214		Pressure boiler
8	Solenoid valve flow restrictor 5l; 230-240V 50/60HZ RAST5	31 06 215		Pressure-independent boiler
8	Solenoid valve flow restrictor 15l; 200-208V 50/60HZ RAST5	31 06 212		Pressure boiler
8	Solenoid valve flow restrictor 5l; 200-208V 50/60HZ RAST5	31 06 213		Pressure-independent boiler
8.1	Solenoid valve filter	31 06 186		
9	Hose clamp; D12-22 X 9	28 02 105		
10	Industrial hose; DN13 X 3,5	40 02 035		570mm; "By-the-metre" goods
11	Shaped hose; DN13 X 3,5 X 716	60003155		to machine no.: 545 173
11	Moulded hose; DN12 X DN13,5 X 3,0	60004287		From machine no.: 545 174
12	Reverse flow inhibitor kit	60003846		to machine no.: 479 915 order too: 570mm x 4002029 + 62003091
12	Reverse flow inhibitor kit	60003846		From machine no.: 479 916 ; Pressure boiler
12	Reverse flow inhibitor kit	60003846		From machine no.: 545 174; For machines without integrated water softener, not for UK and Australia
12	Separate check valve set	60004391		to machine no.: 545 173; Replacement for WSE set (pos. 1) for machines without integrated water softener, not for UK and Australia
12.1	O-ring; 24 X 3,0	27 07 087		
12.2	Hose clamp; D12-22 X 9	28 02 105	4	
13	Cable WMZ; 2 X 0,34QMM	60003179		Pressure-independent boiler and water softener installed
14	Hose; DN10 X 2,0	40 01 050		580 mm; to built-in water softener
15	Shaped hose; DN10 X DN12,50 X 2,0	60003158		to machine no.: 527 466
15	Shaped hose; DN10 X DN12 X 2,0	60004083		From machine no.: 527 467
16	Moulded hose; DN12 X DN13,5 X 3,0	60004288		

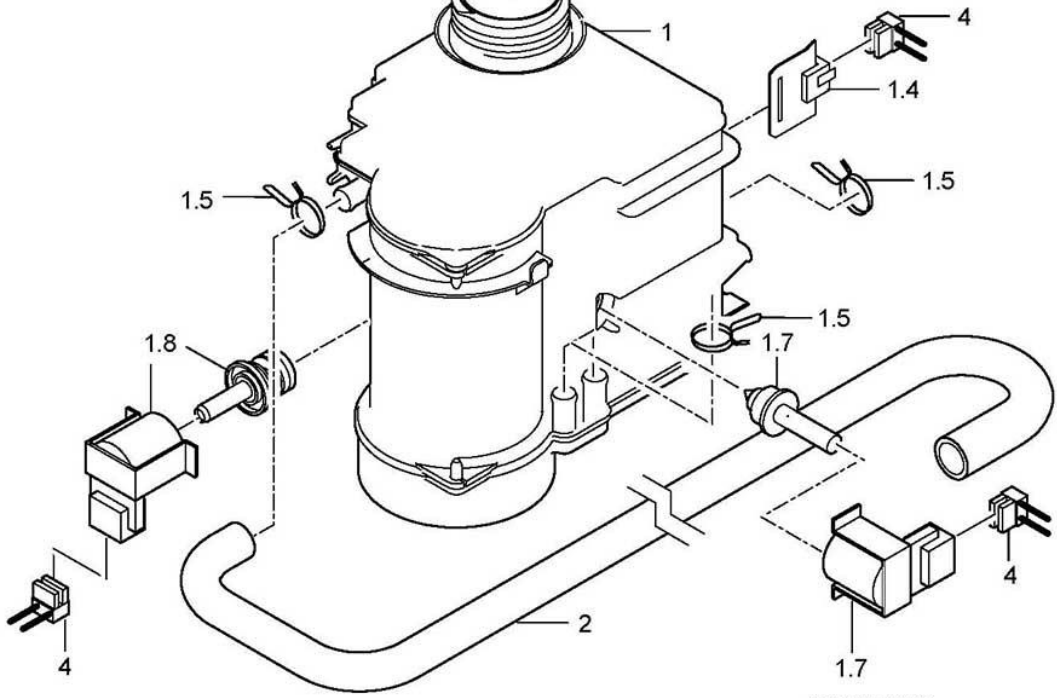
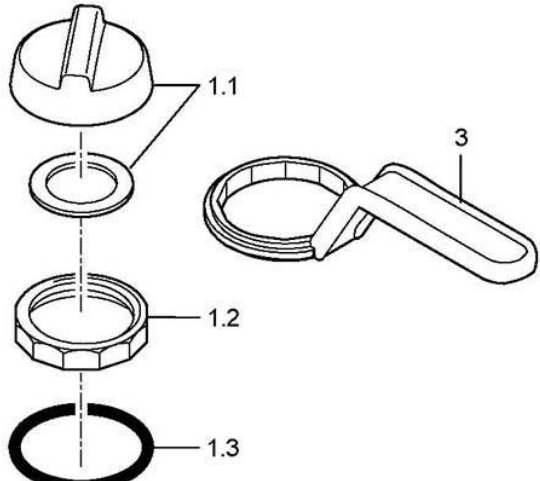
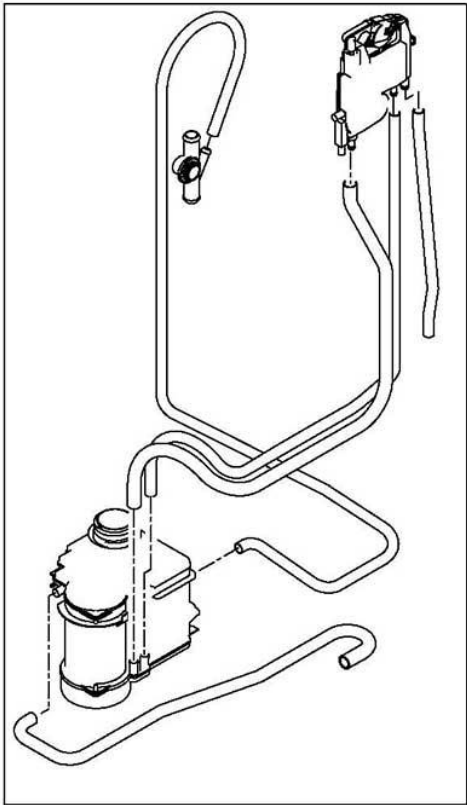

GS215 6200354-00

GS 215

Water softener

Item.	Designation	Parts no.:	Pc.	Notes
1	Water softener kit; 220-240V; 50/60HZ	83000420		
1	Water softener kit; 200-210V; 50/60HZ	83000421		
1.1	Cover, complete, with seal	83000407		
1.2	Lock nut; S54 X 4; D56	60003001		
1.3	O-ring; 54 X 5	27 07 065		
1.4	Dry reed contact lack of salt	83000408		
1.5	Wire hose clamp; D14,4 X 15,1	28 02 344	4	
1.7	Repair kit regeneration valve; 220-240V,50/60HZ	83000402		
1.7	Repair kit regeneration valve; 200-210V,50/60HZ	83000463		
1.8	Repair kit reversing valve; 220-240V,50/60HZ	83000460		
1.8	Repair kit reversing valve; 200-210V,50/60HZ	83000467		
2	Shaped hose; DN10 X DN12,50 X 2,0	60003158		to machine no.: 527 466
2	Shaped hose; DN10 X DN12 X 2,0	60004083		From machine no.: 527 467
3	Double hex ring spanner; SW61,5	60003376		
4	Wiring loom; Water softener	60003185		
o.P.	Filling funnel	35 02 013		

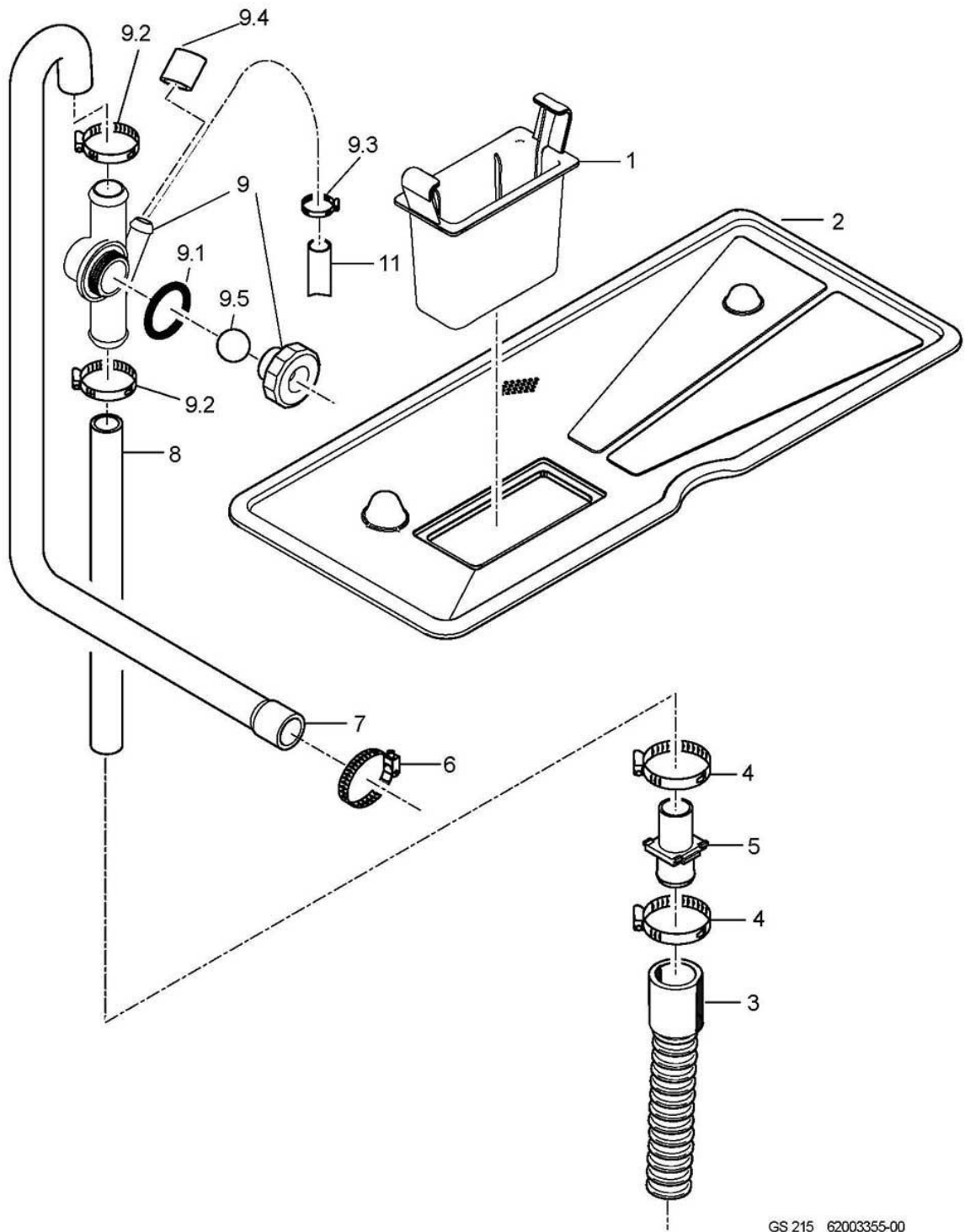

GS 215 62003355-00

GS 215

Water drain

Item.	Designation	Parts no.:	Pc.	Notes
1	Filter cartridge cpl.	60003039		
2	Kit flat filter	60004142		
3	Drain hose; 1500 LG	60003738		
4	Hose clamp; D20-30 X 12	28 02 109		
5	Double nipple; D21,80 X 49; D19	60003399		
6	Hose clamp; D20-30 X 12	28 02 109		
7	Shaped hose; DN18 X DN22; 814	60003281		
8	Reinforced hose; DN19 X 2,5	40 01 046		345 mm; "By-the-metre" goods
9	Deaeration kit	60003514		
9.1	O-ring; 24 X 3,0	27 07 087		
9.2	Hose clamp; D20-30 X 12	28 02 109	2	
9.3	Hose clamp; D10-16 X 9	28 02 307		
9.4	Round cap; D11 X 20	35 03 029		
9.5	Ball; D14	28 01 508		
11	Shaped hose; DN10 X 2,0	60003280		from built-in water softener

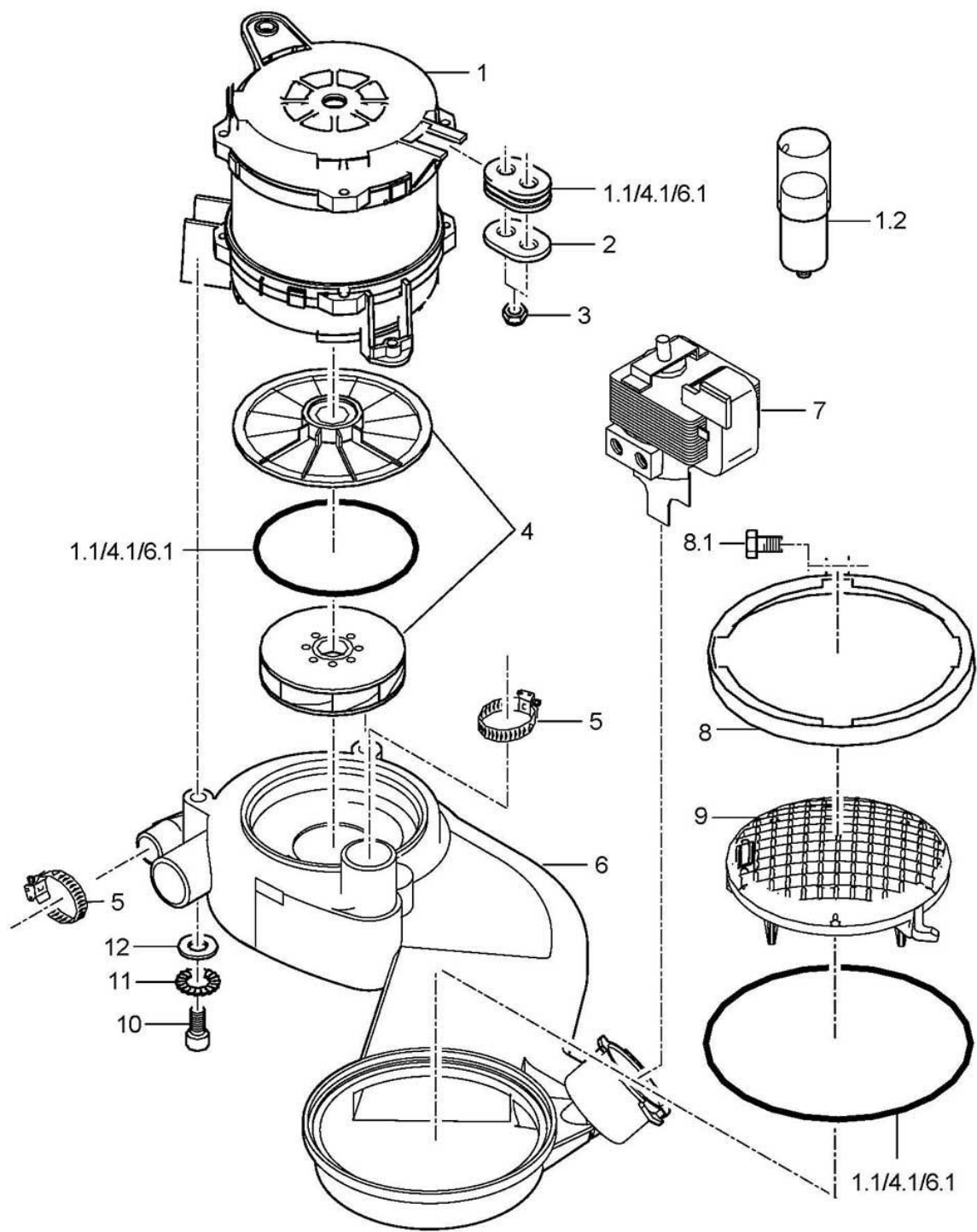

GS215 6200366-00

GS 215

Wash pump

Item.	Designation	Parts no.:	Pc.	Notes
1	Pump motor kit; 230-240V/50-60HZ	60003595		we recommend ordering the set of pump running wheels, as well, when the motor is replaced
1	Pump motor kit; 200V/50-60HZ	60003596		we recommend ordering the set of pump running wheels, as well, when the motor is replaced
1.1	Sealing for pump system kit	60003591		
1.2	Capacitor; 10YF 400V; D35 X 80	31 13 120		
1.2	Capacitor; 12YF 400V;	31 13 122		Japan
2	Spacer washer; 1,25 X 18 X 28	60003298	2	
3	Hexagonal nut; M5 SELBSTSICHERND	21 05 302	4	
4	Impeller with sealings kit; D75	60003593		50 Hz
4	Impeller with sealings kit; D66	60003594		60 Hz
4.1	Sealing for pump system kit	60003591		
5	Hose clamp; D32-52 X 12	28 02 110	2	
6	Collector kit; WASCHSYSTEM UNTEN	60003597		
6.1	Sealing for pump system kit	60003591		
7	Drain pump; 220-240V/50HZ	31 02 480		
7	Drain pump; 200V/50HZ; 220-240V/60H	31 02 493		
7	Drain pump; 200V/60HZ	31 02 495		
8	Pump clip	62003437		
8.1	Hexagon screw; M5 X 40; A70	20 01 329		
9	Filter insert	60003259		
10	Cylinder head screw; M5 X 20; 8,8	20 09 337	3	
11	Serrated lock washer; A-5,3	22 02 316	3	
12	Washer; D5,3 X D10 X 1,0	22 01 300	3	
o.P.	Assembly device, complete	60003450		Tool for exchanging drain pot

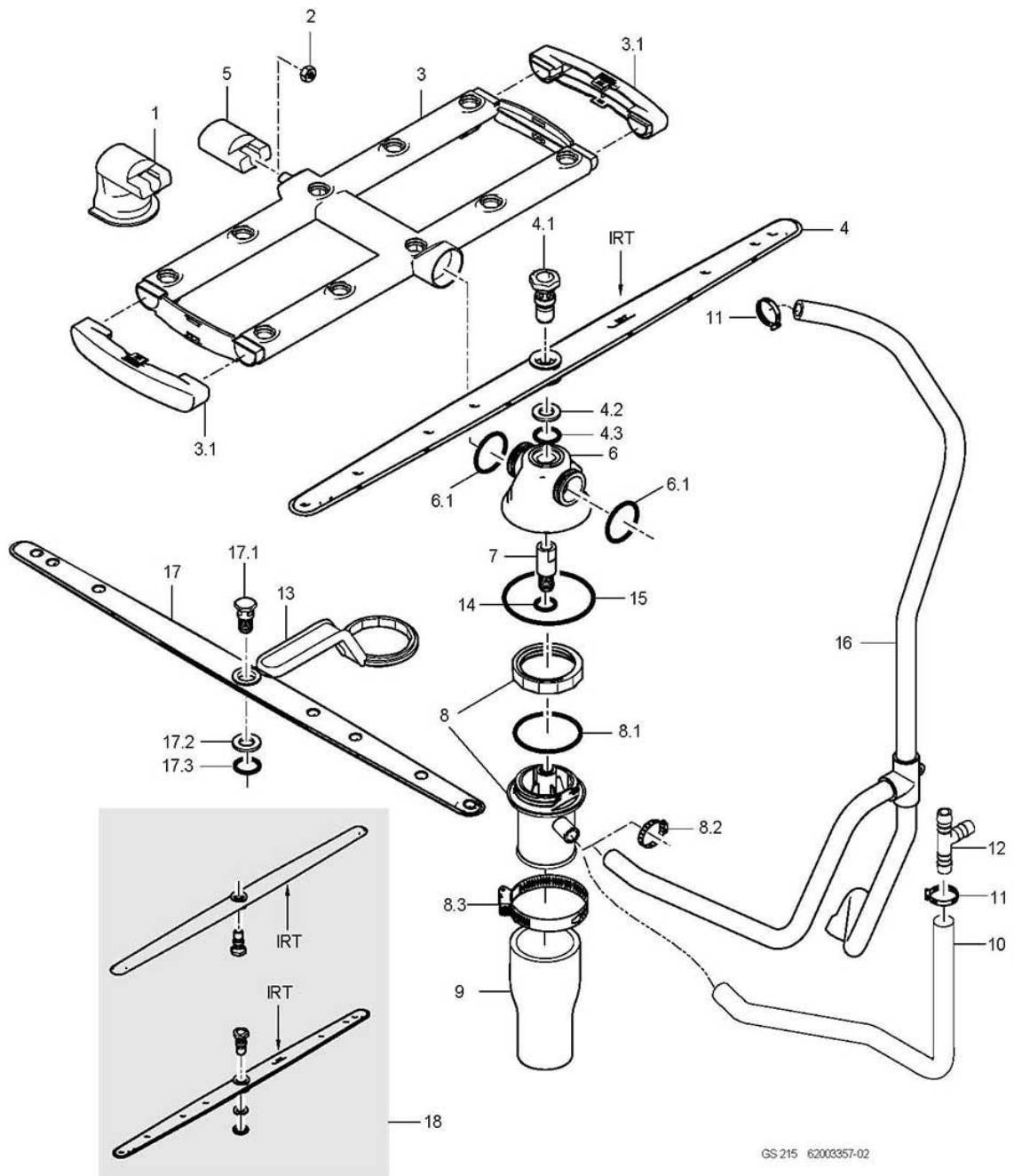

GS 215**Bottom washing/rinsing system**

Item.	Designation	Parts no.:	Pc.	Notes
1	Wash unit support; 70,70 LG	60003435		no longer deliverable; replaced by: Kit flat filter 60004142 (incl. wash unit support)
2	Ratchet nut; M5	21 01 310	2	
3	Wash unit cpl.; 10 DÜSEN; 461 LG	60003803	2	
3.1	End piece; 31,50 X 152	60003802		
4	Rotating rinse arm, min. 2.4 l	61006612		From machine no.: 548 548; For machines with reduced rinse water volume 548 548;
4.1	Rotary arm screw; M12 X 36; SW19	60004123		
4.2	Washer; D12,5 X D24 X 2,5	60003386		
4.3	O-ring; 10 X 2,5	27 07 030		
5	Wash unit support; 58,04 LG	60002999		
6	Distributor top kit	60003516		
6.1	Seal ring; D29,3 X D33,8 X 2,5	60004276	2	
7	Revolving rinse arm spindle; D16 X 44,5; M12	60003043		
8	Distributor bottom kit	62003345		
8.1	O-ring; 56 X 3,0	27 07 086		
8.2	Hose clamp; D12-22 X 9	28 02 105		
8.3	Hose clamp; D47-67 X 12	28 02 115		
9	Reducing hose; DN33 X DN46; 97	60004591		
10	Industrial hose; DN13 X 3,5	40 02 035		460 mm; "By-the-metre" goods
11	Hose clamp; D12-22 X 9	28 02 105		
12	Hose T-connecting piece; D15 X D15 X D15	70010598		Pressure boiler
13	Double hex ring spanner; SW61,5	60003376		
14	O-ring; 10 X 1	27 07 054		
15	O-ring; 66 X 2,5	27 07 011		No longer has to be installed
16	Rinse manifold	62003605		Pressure-independent boiler
17	Rinsing wash arm set; 7 DÜSEN	60003515		to machine no.: 548 547
17.1	Revolving arm screw; M12 X 30; SW19	60003045		no longer deliverable; up to mach. no.: 496 628 replaced by 60003515
17.1	Rotary arm screw; M12 X 36; SW19	60004123		From machine no.: 496 629
17.2	Washer; D12,5 X D24 X 2,5	60003386		
17.3	O-ring; 10 X 2,5	27 07 030		
18	Rotating rinse arm conversion, min. 2.4 l; GS215; GS300; GS502	61006613		to machine no.: 548 547; For machines with non pressurised boilers

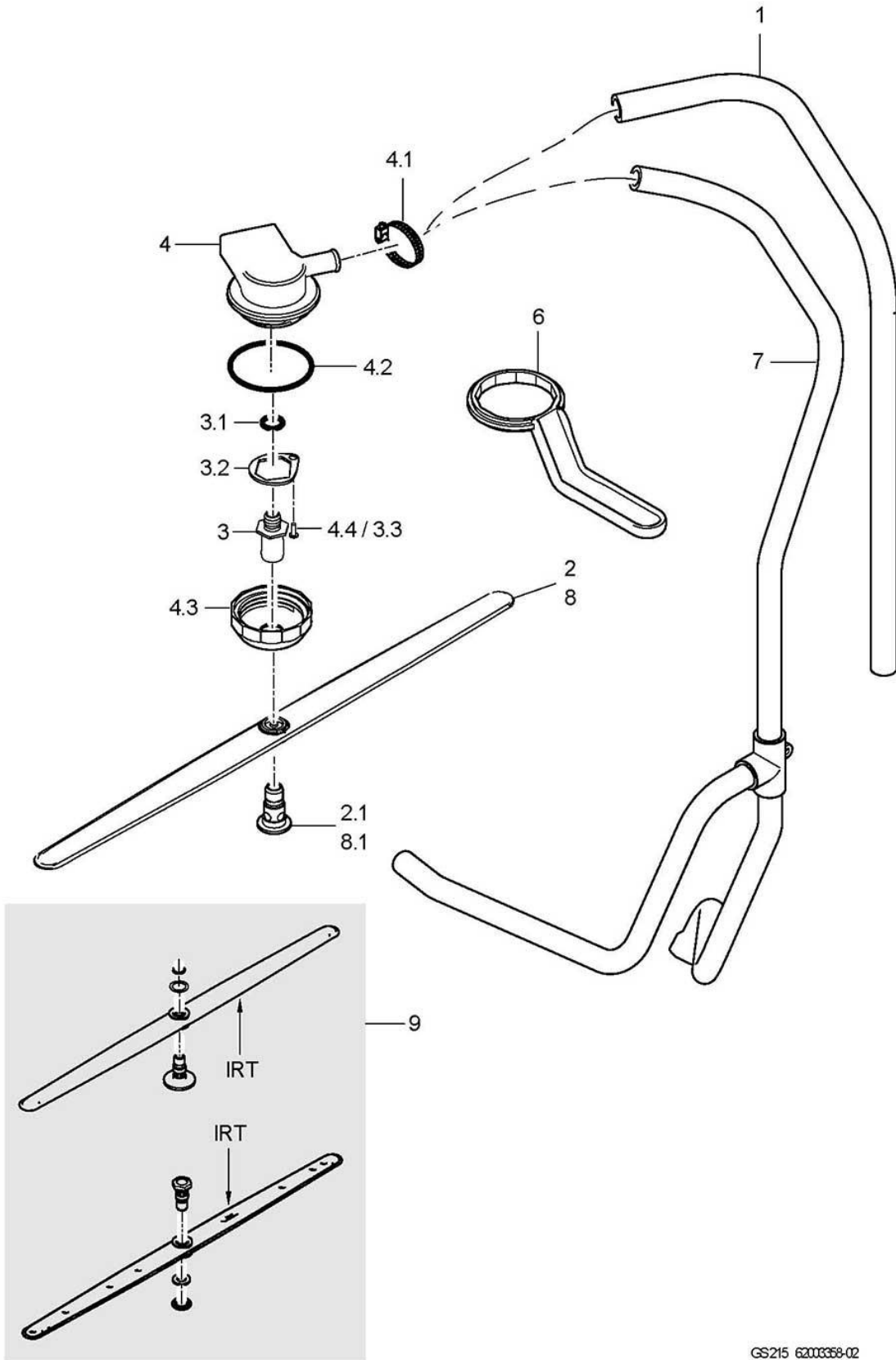

GS215 6200358-02

GS 215

Rinse system top

Item.	Designation	Parts no.:	Pc.	Notes
1	Shaped hose; DN12,5 X DN14 X 3,5	60003160		Pressure boiler
2	Rotating rinse arm, min. 2.4 l	61006612		From machine no.: 548 548; For machines with reduced rinse water volume 548 548;
2.1	Rotary arm screw; M12 X 36; SW19	60004123		
3	Revolving rinse arm spindle kit	60003617		
3.1	O-ring; 10 X 2,5	27 07 030		
3.2	Washer; 1,5 X 28 X 32,3	61006076		
3.3	Sheet metal screw; ST 3,5 X 9,5	20 20 305		
4	Set of water inlets top	62003346		
4.1	Hose clamp; D12-22 X 9	28 02 105		
4.2	O-ring; 56 X 3,0	27 07 086		
4.3	Lock nut; S54 X 4; D57	62003024		
4.4	Sheet metal screw; ST 3,5 X 9,5	20 20 305		
6	Double hex ring spanner; SW61,5	60003376		
7	Rinse manifold	62003605		Pressure-independent boiler
8	Rinsing wash arm set; 7 DÜSEN	60003515		to machine no.: 548 547
8	Rotating rinse arm conversion, min. 2.4 l; GS215; GS300; GS502	61006613		to machine no.: 548 547; For machines with non pressurised boilers
8.1	Revolving arm screw; M12 X 30; SW19	60003045		no longer deliverable; up to mach. no.: 496 628 replaced by 60003515
8.1	Rotary arm screw; M12 X 36; SW19	60004123		From machine no.: 496 629
9	Rotating rinse arm conversion, min. 2.4 l; GS215; GS300; GS502	61006613		to machine no.: 548 547; For machines with non pressurised boilers

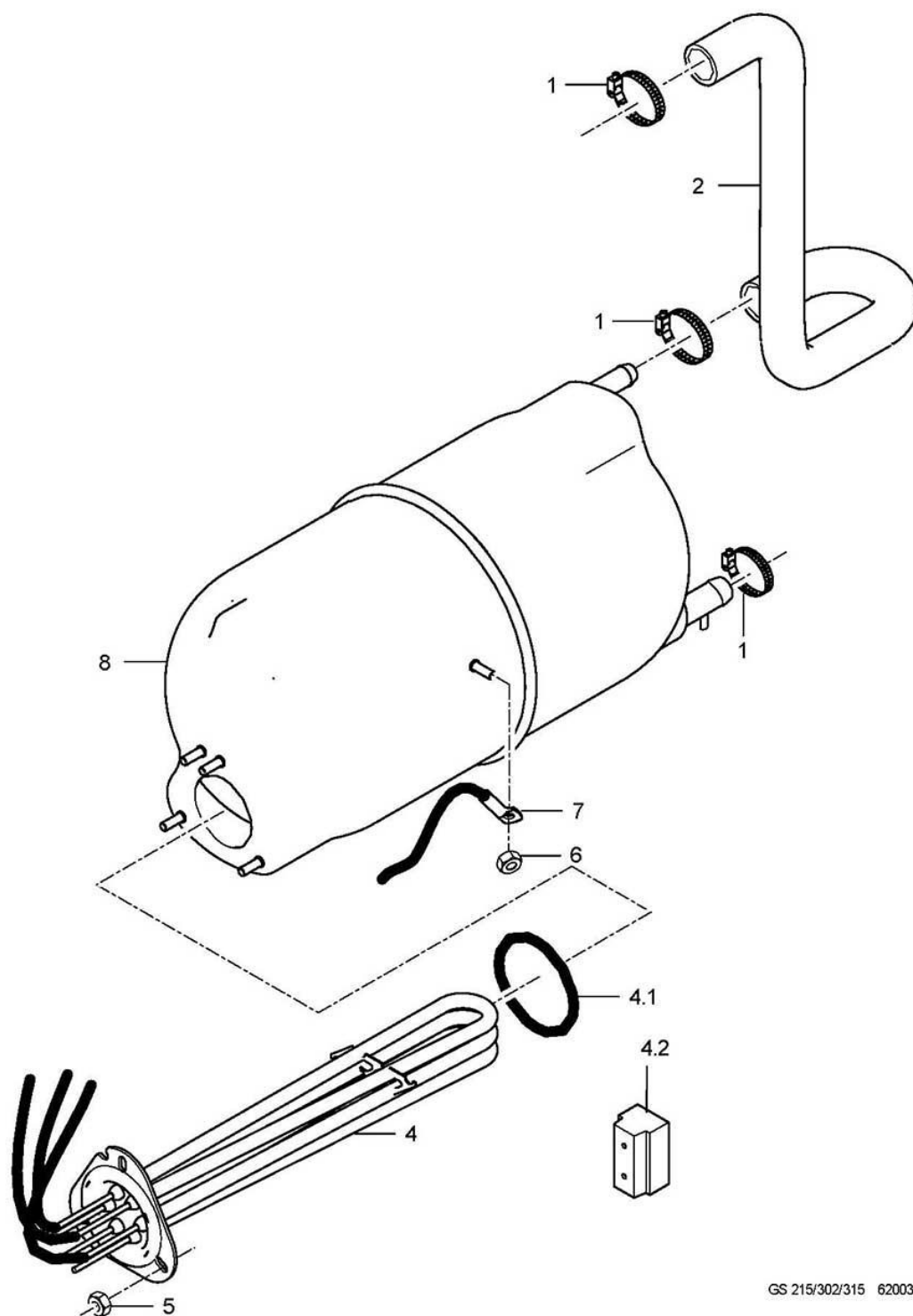

GS 215/302/315 62003359-00

GS 215

Pressure boiler

Item.	Designation	Parts no.:	Pc.	Notes
1	Hose clamp; D12-22 X 9	28 02 105		
2	Shaped hose; DN12,5 X 3,5 X 286	60003162		
4	Heater with fuse; 5.0kW; 3 X 380-420V	60003598		Rotary current (star connection)
4	Heater with fuse; 5.0kW; 3 X 240V DREIECK	60003599		Rotary current (delta connection)
4	Heater with fuse; 5.0kW; 3 X 200-208V STERN	60003600		
4	Heater with fuse; 5.0kW; 3 X 380-420V STERN	60003601		Rotary current (Australia)
4	Heater with fuse; 5.0kW; 3 X 440-460V STERN	60003833		
4	Heater with fuse; 3.5kW; 3 X 400V STERN	60003602		Rotary current (fuse protection 10A)
4	Heater with fuse; 4.0kW; 1 X 220-240V	60003604		Alternating current (fuse protection 25A; UK)
4	Heater with fuse; 2.6kW; 1 X 220-240V	60003605		Alternating current (fuse protection 16A)
4	Heater with fuse; 2.6kW; 1 X 240V	60003606		Alternating current (fuse protection 16A; Australia)
4	Heater with fuse; 2.6kW; 1 X 208V	60003607		Alternating current (fuse protection 20A; Japan, USA)
4	Heater with fuse; 1.8kW; 1 X 220-240V	60003610		Alternating current (fuse protection 13A; UK)
4.1	O-ring; 46 X 6,0	27 07 085		
4.2	Appliance terminal G10/4; 4-POLIG; 10QMM	31 09 227		
5	Hexagonal nut; M5	21 01 203	3	
6	Ratchet nut; M5	21 01 310		
7	Thermal sensor kit 1700mm	80003804		with heat-conducting foil
8	Pressure boiler cpl.	60002916		

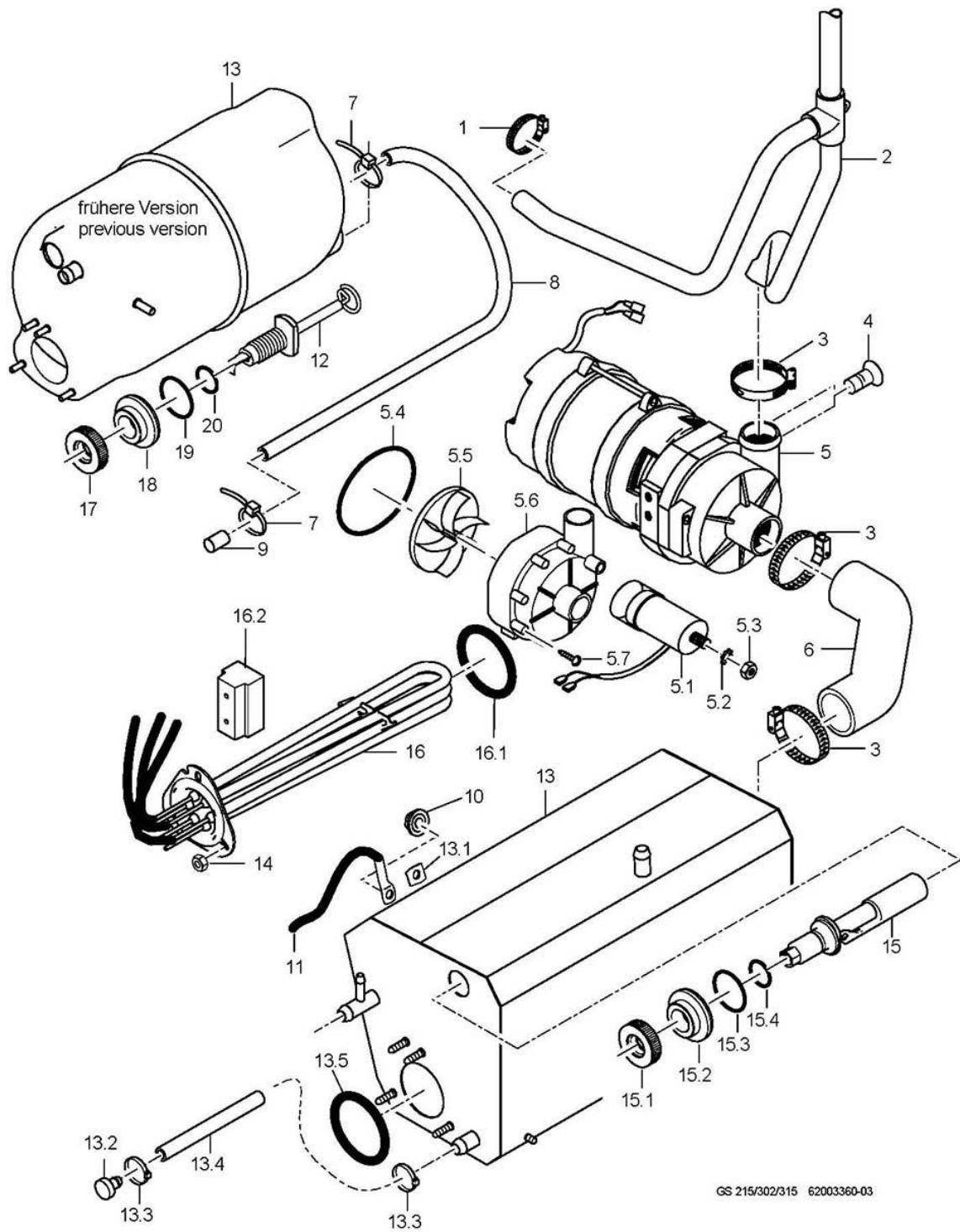

GS 215

Pressure-independent boiler

Item.	Designation	Parts no.:	Pc.	Notes
1	Hose clamp; D12-22 X 9	28 02 105		
2	Rinse manifold	60003831		
3	Hose clamp; D24-36 X 12	28 02 111		
4	Countersunk screw; M6 X 16	20 12 319	2	
5	Pump 0.14kW 3/3; 220V/240V/1/50HZ	31 02 561		Repair recommended only for pump housings with 7 screws
5	Pump 0.27kW 3/3; 220V/240V/1/60HZ	31 02 461		Repair recommended only for pump housings with 7 screws
5	Pump 0.27kW 3/3; 200V/1/50HZ	31 02 462		Repair recommended only for pump housings with 7 screws
5	Pump 0.27kW 3/3; 200V/1/60HZ	31 02 463		Repair recommended only for pump housings with 7 screws
5.1	Capacitor; 4 MIKRO F / 400V	31 13 171		Pump 0,14kW
5.1	Capacitor; 5 MIKRO F	31 13 099		Pump 0,27kW
5.2	Spring washer; B8	23 03 301		
5.3	Hexagonal nut; M8	21 01 305		
5.4	Cord; D=78 X 3; SHOR 50-55;	40 04 023		
5.5	Pump impeller; FÜR UP60/UP30 MIT 50HZ	31 02 466		50 Hz
5.5	Pump impeller, installed; FÜR UP60 MIT 60HZ	31 02 587		60 Hz
5.6	Pump housing; D=80,5MM	31 02 519		
5.7	Screw for pump housing	31 01 118	7	
6	Shaped hose; DN25 X 4,0; 140	60002973		
7	Cable tie; 100 X 2,5	31 20 175		
8	Hose; DN5 X 1,5	40 01 024		900 mm; "By-the-metre" goods
9	Bolt; D6 X 30	70200383		
10	Ratchet nut; M5	21 01 310		
11	Thermal sensor kit 1700mm	80003804		with heat-conducting foil
12	Floating switch installation set	55 28 255		Replacement for: 5528292 (Built-in electrode)
12.1	Nut; M14 X 2, D26,8 X 8	60003989		
12.2	Ring; D14,3 X D32 X 11	60003872		
12.3	O-ring; 23 X 3,5	27 07 093		
12.4	O-ring; 11,11 X 1,78	27 07 079		
13	Pressure-independent boiler	60004174		includes all necessary hoses
13.1	Heat conducting foil with hole; 0,25 X 12 X 15	61005285		
13.2	Plug; D24 X D13,1 X 27	70007962		
13.3	Hose clamp; D12-22 X 9	28 02 105		
13.4	Hose; D10 X 2	40 02 034		
13.5	O-ring; 46 X 6,0	27 07 085		
14	Hexagonal nut; M5	21 01 203	3	
15	Floating switch installation set	55 28 255		
15.1	Nut; M14 X 2, D26,8 X 8	60003989		
15.2	Ring; D14,3 X D32 X 11	60003943		
15.3	O-ring; 24 X 3,0	27 07 087		
15.4	O-ring; 11,11 X 1,78	27 07 079		

For missing items, see next page

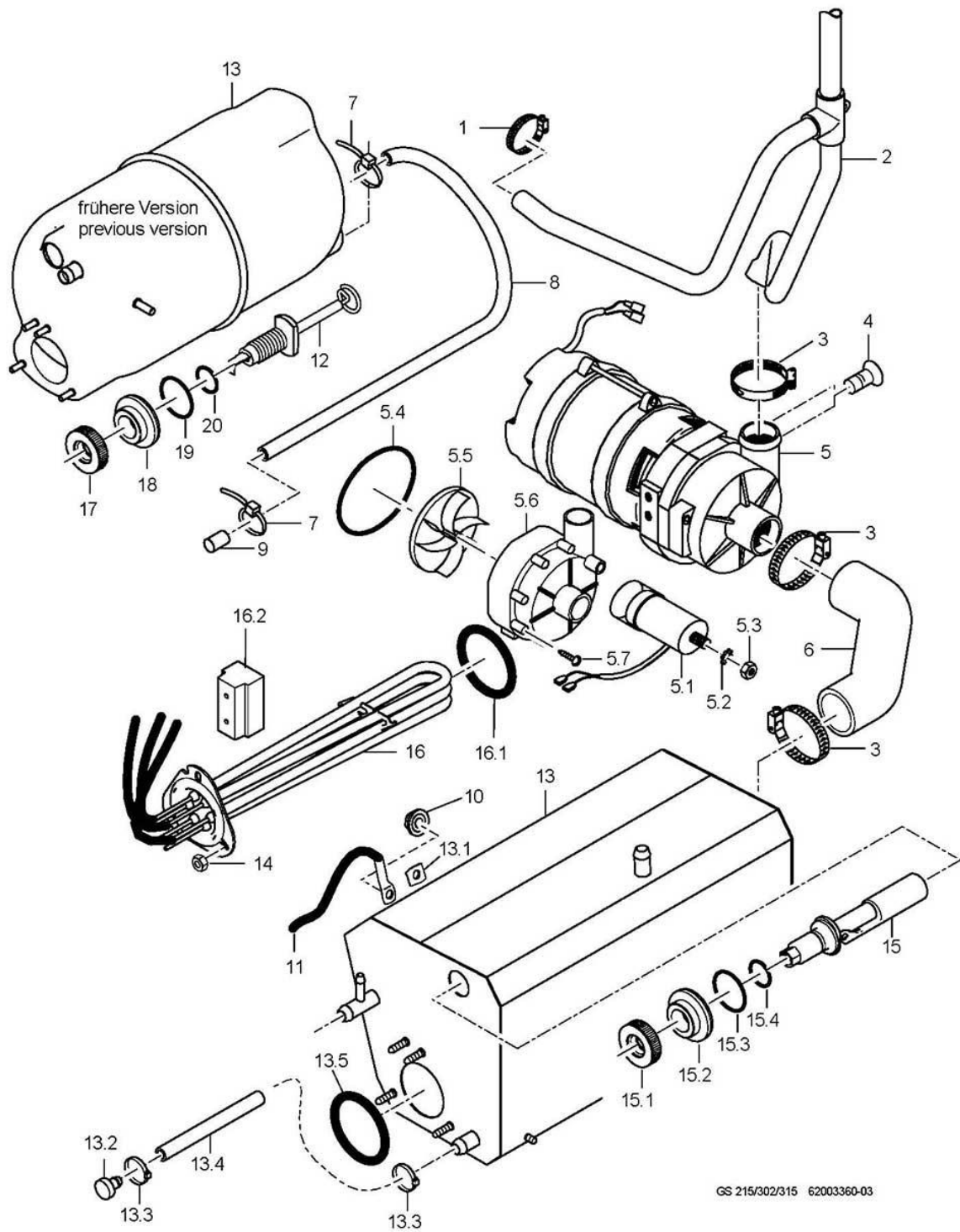

GS 215

Pressure-independent boiler

Item.	Designation	Parts no.:	Pc.	Notes
16	Heater with fuse; 5.0kW; 3 X 380-420V	60003598		Rotary current (star connection)
16	Heater with fuse; 5.0kW; 3 X 240V DREIECK	60003599		Rotary current (delta connection)
16	Heater with fuse; 5.0kW; 3 X 200-208V STERN	60003600		
16	Heater with fuse; 5.0kW; 3 X 380-420V STERN	60003601		Rotary current (Australia)
16	Heater with fuse; 5.0kW; 3 X 440-460V STERN	60003833		
16	Heater with fuse; 3.5kW; 3 X 400V STERN	60003602		Rotary current (fuse protection 10A)
16	Heater with fuse; 4.0kW; 1 X 220-240V	60003604		Alternating current (fuse protection 25A; UK)
16	Heater with fuse; 2.6kW; 1 X 220-240V	60003605		Alternating current (fuse protection 16A)
16	Heater with fuse; 2.6kW; 1 X 240V	60003606		Alternating current (fuse protection 16A; Australia)
16	Heater with fuse; 2.6kW; 1 X 208V	60003607		Alternating current (fuse protection 20A; Japan, USA)
16	Heater with fuse; 1.8kW; 1 X 220-240V	60003610		Alternating current (fuse protection 13A; UK)
16.1	O-ring; 46 X 6,0	27 07 085		
16.2	Appliance terminal G10/4; 4-POLIG; 10QMM	31 09 227		
17	Nut; M14 X 2, D26,8 X 8	60003989		
18	Ring; D14,3 X D32 X 11	60003872		
19	O-ring; 24 X 3,0	27 07 087		
20	O-ring; 11,11 X 1,78	27 07 079		

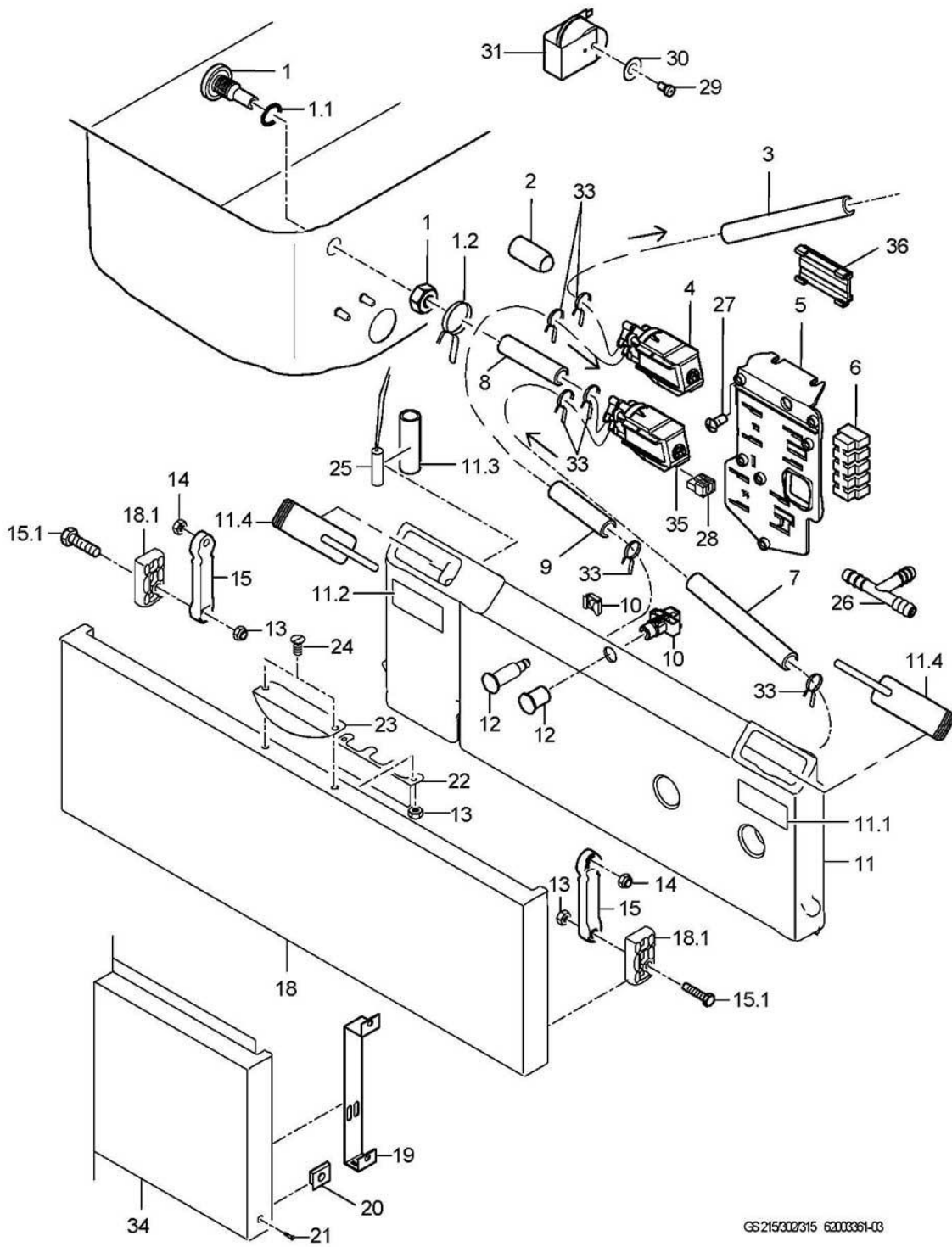

GS215302/315 62003361-03

GS 215

Dosage

Item.	Designation	Parts no.:	Pc.	Notes
1	Dosing nipple set, M10 X 29; SW5	61005883		
1.1	O-ring; 10 X 2,5	27 07 030		
1.2	Wire hose clamp; D8,6 X 1	28 02 348		
2	End cap; D5,7 X 25,4	35 06 180		
3	Hose; DN5 X 1,5	40 01 024		900 mm; "By-the-metre" goods
4	Fluidos DB "Rinse aid" kit; 115-240V/50-60HZ	31 02 598		
5	Adapter plate; 1,5 X 80 X 100	60003688		
6	Binding post; 5-POLIG; 6QMM; 56,5LG	31 09 230		for connecting external dispenser
7	Hose; DN5 X 1,5	40 01 024		600 mm; "By-the-metre" goods
8	Hose; DN5 X 1,5	40 01 024		300 mm; "By-the-metre" goods
9	Hose; DN5 X 1,5	40 01 024		800 mm; "By-the-metre" goods
10	Captive nut; M8	21 13 006		to machine no.: 493 480
10	Stud bolt; M8 X 37; M12	60003658		from mach. no. 493 481
11	Detergent container	60003747		
11.1	Label detergent; 0,2 X 28 X 65	60003330		
11.2	Label -Rinse Aid-; 0,2 X 28 X 65	60003310		
11.3	Hose; DN5 X 1,5	40 01 024		50 mm; "By-the-metre" goods
11.4	Cover	60003974		retrofitable; for both sides
12	Magnet support	60003643		to machine no.: 493 480
12	Magnet support	60003952		from mach. no. 493 481
13	Hexagonal nut; M4 SELBSTSICHERND	21 05 300		
14	Hexagonal nut; M5 SELBSTSICHERND	21 05 302	3	
15	Set of levers	60003778		
15.1	Hexagon screw; M4 X 18	20 01 320		
18	Set of detergent flaps	60004140		with detergent, freshwater rinse dispenser
18.1	Profile; 12,5 X 28 X 50	60003569	2	
19	Bracket; 1,25 X 25 X 243,08	60003823		without detergent, freshwater rinse dispenser; From machine no.: 480 029
20	Sheet metal nut; B 3,9	21 17 301		
21	Sheet metal screw; ST 3,9 X 13	20 20 310		
22	Elbow; 1,0 X 43 X 100	60003633		
23	Handle kit	60003650		
24	Countersunk screw; M4 X 10	20 12 312		
25	Magnetic switch; 25,5 X D5,75; 2250 LG	31 24 240		
26	T-hose socket; D6	29 06 516		Additional equipment
27	PT screw; KB 60 X 12	20 17 308	2	
28	Macro-module plug; RAST5; 4-POLIG UNCOD.	31 12 094		
29	Raised head screw; M3 X 10	20 10 004		
30	Washer; D5,3 X D15 X 1,2	22 05 301		
31	Buzzer; 230VAC; 75DB; 23X30,5MM	31 13 133		Additional equipment
31	Set of acoustical level indicators; WPS MAX. VORHANDEN	55 28 281		with max. WPS version
31	Set of acoustical level indicators; WPS MAX.NICHT VORHAND.	55 28 282		with min. WPS version
33	Wire hose clamp; D8,6 X 1	28 02 348		
34	Front panelling, complete	60003827		without detergent, freshwater rinse dispenser; up to mach. no. 480028; order too: 2x60003823
34	Front panelling, complete	60003827		without detergent, freshwater rinse dispenser; From machine no.: 480 029
35	Fluidos DT "Detergent" kit; 115-240V/50-60HZ	31 02 597		
36	Adapter; 11,4 X 33,5 X 57,5	80003775		From machine no.: 1001846

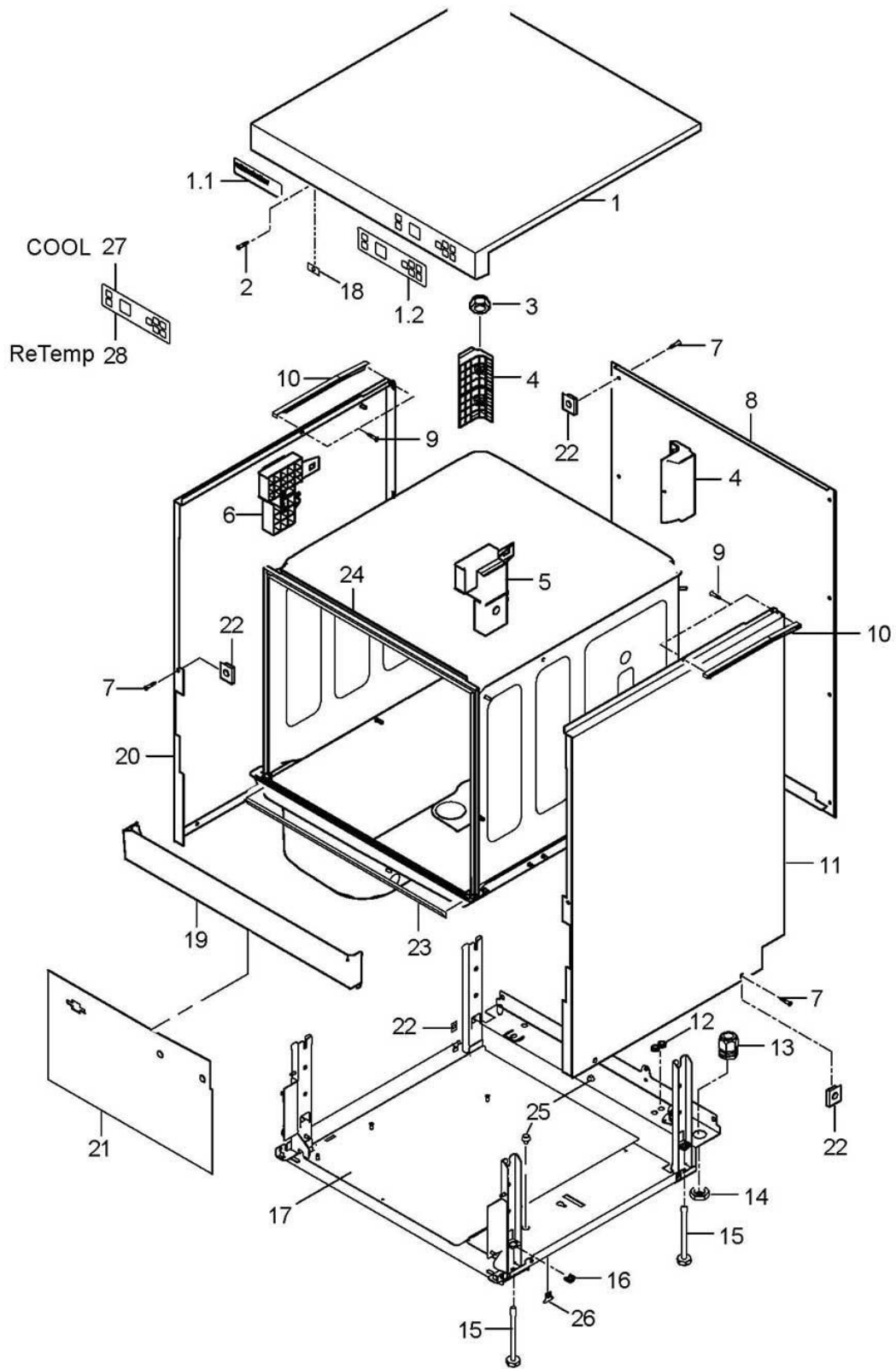

GS215 6200362-01

GS 215

Chassis, container and panelling

Item.	Designation	Parts no.:	Pc.	Notes
1	Cover plate kit	60003521		
1.1	Plate -Winterhalter GS 215-; 0,175 X 35 X 126	62003678		
1.1	Plate -Winterhalter GS 302-; 0,175 X 35 X 126	60004381		
1.1	Plate -Winterhalter GS 315-; 0,175 X 35 X 126	60004382		
1.2	Pad -Operating Panel-; 0,175 X 50 X 180	31 24 223		
2	Plate screw; ST 3,9 X 13	20 21 302	2	
3	Ratchet nut; M5	21 01 310		
4	Support corner rear	60003010	2	
5	Support corner front right	60003009		
6	Support corner left	60003008		
7	Sheet metal screw; ST 3,9 X 13	20 20 310	16	
8	Rear cover	62003547		Plastic; only for machines with foil tank heater
8	Rear cover	62003794		high grade steel; Additional equipment
9	Plate screw; ST 3,9 X 13	20 21 302	2	
10	Slide for cover panel; 250,50 LG	60003501		
11	Housing panel right	62003198		
12	Hose nozzle; 6,25 X D15; D8,5	61004890	2	
13	Cable gland; M25 X 1,5;9-17MM;IP68	31 10 153		
14	Hexagonal nut; M25 X 1,5 X 6,0; SW32	31 10 163		
15	Adjustable foot; M8 X 129; SW24	60004274	4	
16	Captive nut; M8	21 13 006	4	
17	Bottom plate, complete	60003441		to machine no.: 473 308
17	Base plate; 2,0 X 444,5 X 479	60003749		From machine no.: 473 309
18	Plate nut; B 3,9	21 17 100	2	
19	Panel; 1,0 X 149,23 X 703,38	60003754		
20	Housing panel left compl.	62003197		
21	Protective film; 0,185 X 196 X 330	60003838		retrofitable
22	Sheet metal nut; B 3,9	21 17 301	16	
23	Rubber profile; 6,0 X 12 X 570	60003847		
24	Adhesive tape; 9 BREIT;2 DICK X 10000	48 03 022	1	1 roll = 1 m
25	Buffer; D8 X 14	40 06 023	2	
26	Latch; 1,5 X 18,9 X 23,9	60003732	2	
27	Pad -Operating Panel Cool-; 0,175 X 50 X 180	31 24 269		
28	Pad Operating Panel ReTemp; 0,175 X 50 X 180	31 24 282		
o.P.	Set of vapour protectors, cpl.	80002870		Additional equipment

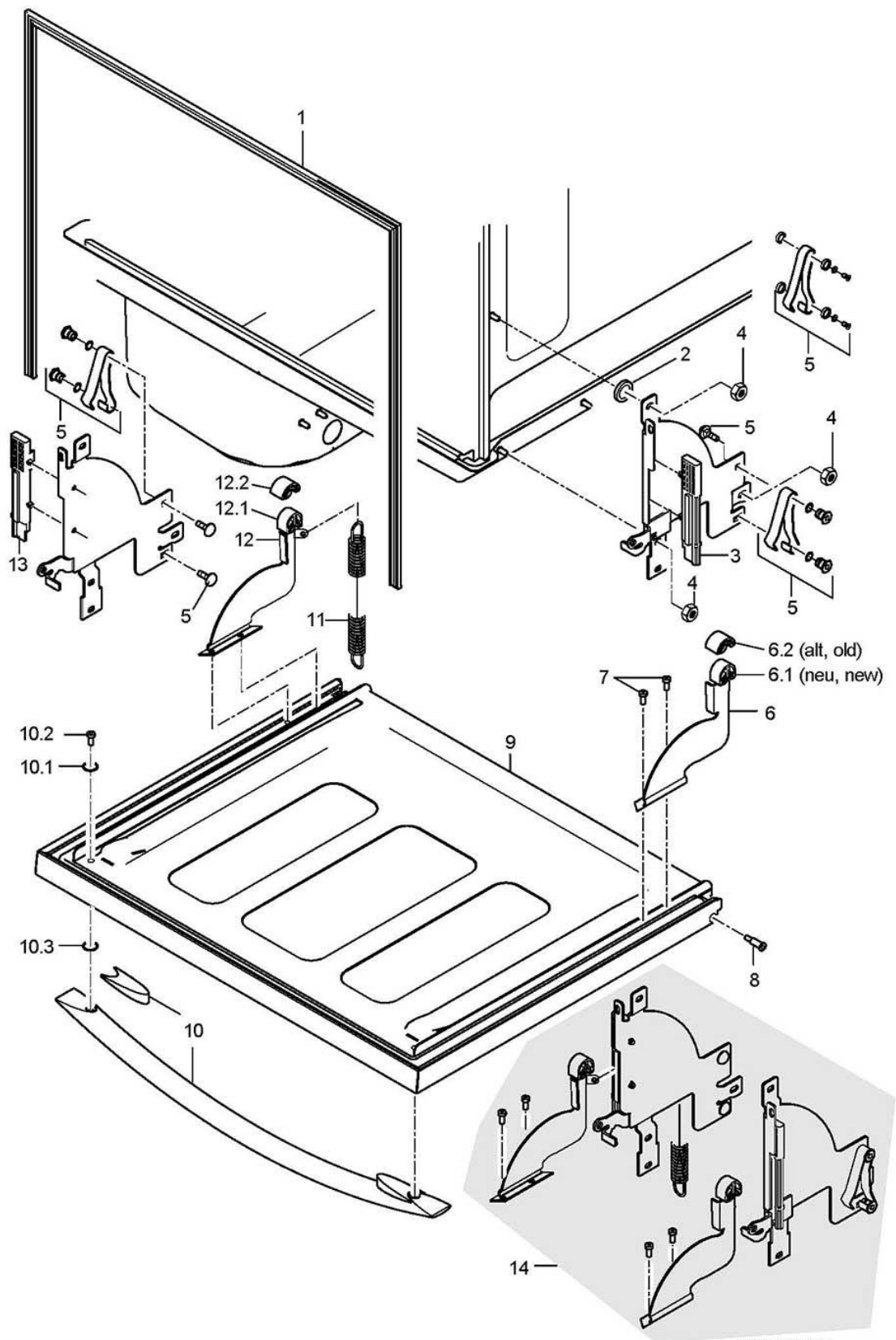

GS215 63003663.02

GS 215

Door

Item.	Designation	Parts no.:	Pc.	Notes
1	Door seal	62003066		
2	Washer; D5,3 X D15 X 1,2	22 05 301		
3	Right stop	60003411		
4	Hexagonal nut; M5 SELBSTSICHERND	21 05 302	3	
5	Leaf spring repair kit	60003743		for both sides; up to mach. no.: 494 758
5	Leaf spring repair kit; 9MM	62003595		for both sides; from mach. no. 494 759
6	Brace right, offset, cpl.	60003995		incl. item 6.1 - 6.2
6.1	Sliding roller	60003870		
6.2	Sliding roller	60003214		
7	Cylinder head screw; M5 X 12	20 03 307	2	
8	Door bearing bolt; D9 X D7,0 X M5; SW4	60003147	2	
9	Door cpl.	62002980		without door handle
10	Door handle kit	60003522		
10.1	O-ring; 5 X 1,2	27 07 070	2	
10.2	Oval head screw with hexagonal socket; M5 X 30 MIT FLANSCH	20 10 308	2	
10.3	O-ring; 6 X 2	27 07 012	2	
11	Tension spring; L0=193;L1=360;F1=82	60003697	1	
12	Brace left, offset, cpl.	60003994		incl. item 12.1 - 12.2
12.1	Sliding roller	60003870		
12.2	Sliding roller	60003214		
13	Left stop	60003410		
14	Hinge conversion kit 215	62003597		produced in series starting with machine no.: 494 759
o.P.	Silicone adhesive Elastosil E43; 90 ML	34 03 012		for door seals

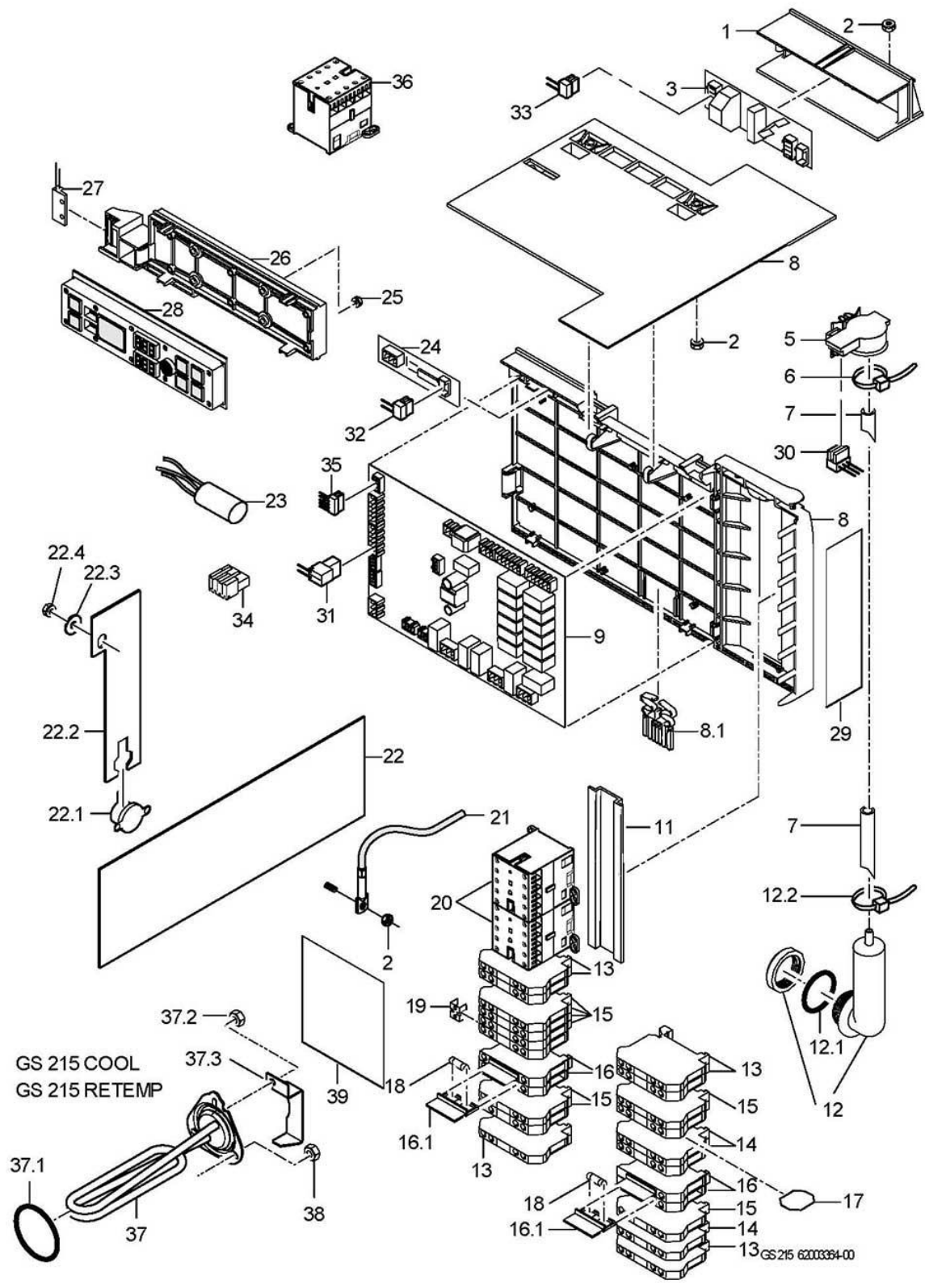

GS 215

Electric parts

Item.	Designation	Parts no.:	Pc.	Notes
1	Protective cover; SCHWARZ	60003541		
2	Ratchet nut; M5	21 01 310	4	
3	Soft start WSA4	31 13 180		
5	Pressure transmitter; 0-30MBAR;5VDC/0,5-3,5V	31 26 044		
6	Cable tie; 100 X 2,5	31 20 175		
7	Hose; DN5 X 1,5	40 01 024		750 mm; "By-the-metre" goods
8	Assembly plate	60003660		incl. item 8.1
8.1	Latch; SCHWARZ	60003356		
9	Programme control WPS MAX Kit; 180-265V; 50/60HZ	31 05 139		
11	Snap-on rail; 1,0 X 35 X 185	60003244		
12	Air chamber set	60003525		
12.1	O-ring	30000196		
12.2	Wire hose clamp; D8,6 X 1	28 02 348		
13	UDK 4-PE double terminal	31 09 153	3	
14	UDK 4 double terminal	31 09 151		
15	UDK 4 BU double terminal	31 09 152		
16	Universal fuse clip	31 09 063	2	
16.1	Securing plug	31 09 072		
17	Isolating disc; 14 X 16	31 09 169		
18	Fine fuse, medium time lag; 250V; 4,0A; 5 X 20	31 11 123	2	has been reduced from 6.3A to 4.0A
19	Fixed bridge; 2-POLIG;	31 09 126		
20	Contacteur B7:3H 1 N/C contact; 220-255V/50-60HZ	31 04 154	2	
20	Contacteur B7:3H 1 N/C contact; 200V/50-60HZ	31 04 171	2	Japan; USA
20	Contacteur B7:3H:1Ö; 208V/50-60HZ	31 04 176	2	
21	Thermal sensor kit 1700mm	80003804		with heat-conducting foil
22	Foil heating element 600 watts; 230V; 310 X 115MM	60003653		
22	Foil heating element 600 watts; 208V; 310 X 115MM	60003654		Japan; USA
22.1	Safety thermostat; 185 GRAD C MAN.RÜCKST.	31 25 053		
22.2	Retainer; 1,0 X 35 X 110,7	60003939		
22.3	Washer; D5,3 X D15 X 1,2	22 05 301		
22.4	Hexagonal nut; M5 SELBSTSICHERND	21 05 302		
23	Radio interference suppression capacitor; 0,27MF + 2 X 27000PF	31 13 078		
24	Level sensor, electronic; 12V; 7MA; 80 X 20 MM	31 13 164		Pressure-independent boiler
25	Nut-and-washer assembly; M3	21 01 312	4	
26	Support for operating panel	60003350		
27	Magnetic switch; 32 X 14,9 X 6,9; 400LG	31 24 229		
28	Operating panel; 25 X 55 X 210	31 24 222		
29	Protective film; 0,185 X 52 X 195	60003764	2	retrofitable
30	Pressure transmitter cable; 3 X 0,34QMM	60003355		
31	Wiring loom; Water softener	60003185		
32	Cable for level sensor; 2 X 0,34QMM	60003175		
33	Wiring loom; Soft start	60003475		

For missing items, see next page

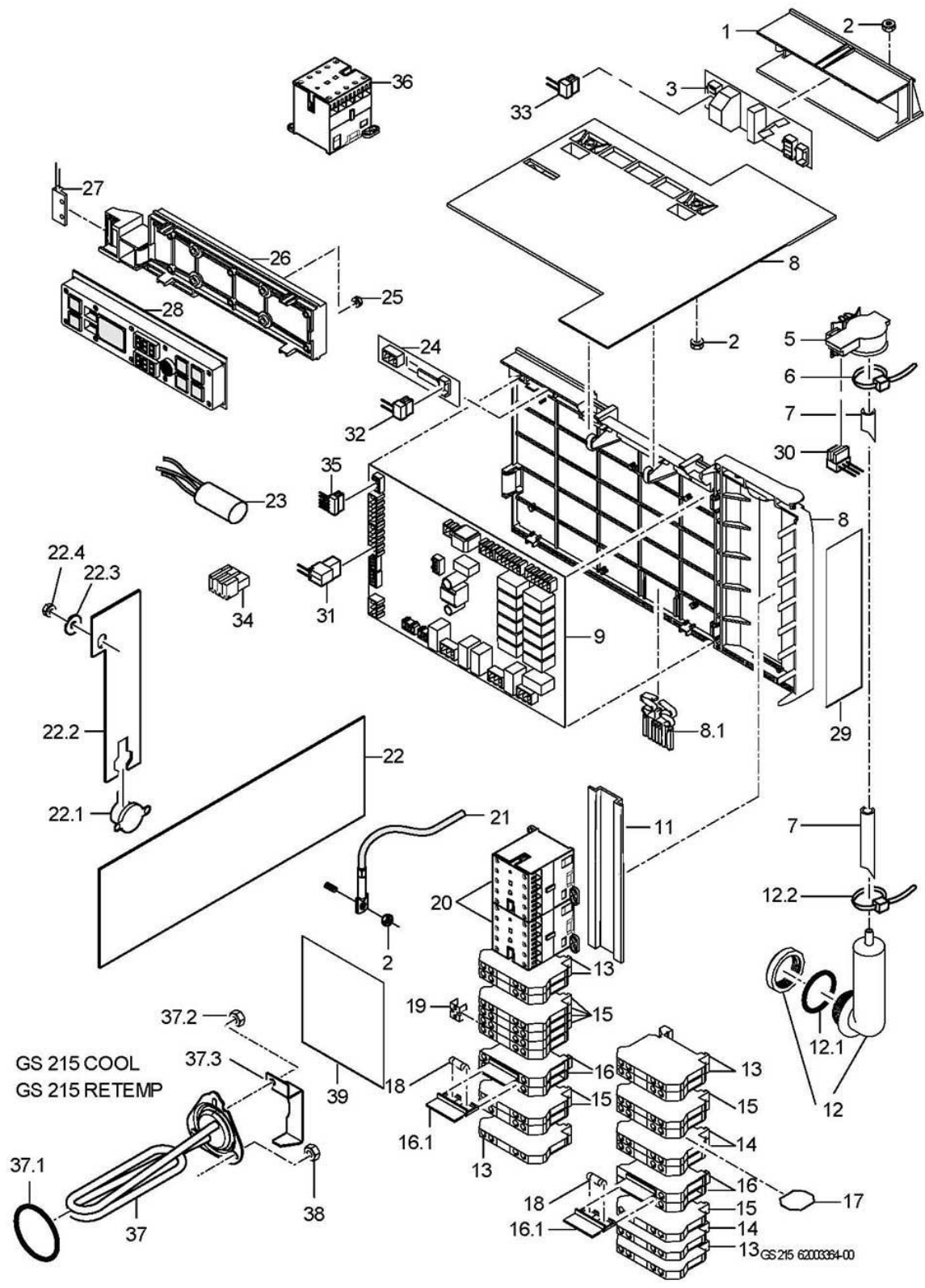

GS 215

Electric parts

Item.	Designation	Parts no.:	Pc.	Notes
34	Macro-module plug; RAST5; 2-POLIG; UNCOD.	31 12 091		
34	Macro-module plug; RAST5;3-POLIG UNCOD.	31 12 093		
34	Macro-module plug; RAST5;4-POLIG UNCOD.	31 12 094		
34	Macro-module plug; RAST2,5;3-POLIG UNCOD.	31 12 095		
34	Macro-module plug; RAST2,5;5-POLIG UNCOD.	31 12 096		
35	Cable bus; 5 X 0,34QMM	60003174		
36	Contacto B7:3H 1 N/C contact; 220-255V/50-60HZ	31 04 154		GS 200 Cool + ReTemp
36	Contacto B7:3H 1 N/C contact; 200V/50-60HZ	31 04 171		GS 200 Cool + ReTemp
37	Heater with fuse kit, 2.6kW; 1 X 220-240V	60004704		GS 200 Cool + ReTemp
37	Heater with fuse kit, 5.0kW; 3 X 380-420V	60004705		GS 200 Cool + ReTemp
37	Heater with fuse kit, 5.0kW; 3 X 230V	60004706		GS 200 Cool + ReTemp
37	Heater with fuse kit, 5.0kW; 3 X 200V	60004707		GS 200 Cool + ReTemp
37.1	O-ring; 46 X 6,0	27 07 085		GS 200 Cool + ReTemp
37.2	Hexagonal nut; M5 SELBSTSICHERND	21 05 302		
37.3	Bracket; 1,25 X 26,25 X 101,55	60004621		
38	Hexagonal nut; M5	21 01 203	3	GS 200 Cool + ReTemp
39	Protective film; 0,31 X 100 X 100	60004267		GS 200 Cool + ReTemp